

GPON OLT Class C+ SFP Transceiver

Widely used in Gigabit-capable Passive Optical Networks (GPON) Class C+ 20Km 17~32dB attenuation range



• Description

- Complies with SFP Multi-Source Agreement (MSA) SFF-8074i
- Complies with SFF-8472 Rev 9.5
- Complies with ITU-T G.984.2 Amendment 2
- Complies with FCC 47 CFR Part 15, Class B
- Complies with FDA 21 CFR 1040.10 and 1040.11
- Single fiber bi-directional data links asymmetric TX 2488Mbps / RX1244Mbps application
- 1490nm continuous-mode DFB laser transmitter and 1310nm burst-mode APD-TIA receiver
- Small Form Factor Pluggable package with SC/UPC Connector

• Advantages

- Support Class C+ 17~32dB attenuation range application (With FEC)
- Reset burst-mode receiver design support more than 15dB dynamic range
- 0 to 70°C operating temperature
- Single 3.3V power supply
- Digital diagnostic monitoring interface
- Digital burst RSSI function to monitor the input optical power level
- LVPECL compatible data input/output interface
- LVTTTL transmitter disable control
- LVTTTL transmitter laser fault alarm
- LVTTTL receiver Signal Detect (SD) indication response within 50ns.
- Low EMI and excellent ESD protection
- Class I laser safety standard IEC-60825 compliant
- RoHS-6 compliance

• Table 1- Absolute Maximum Ratings

Parameter	Symbol	Min.	Max.	Unit	Notes
Storage Ambient Temperature	T _{STG}	-40	85	°C	
Operating Case Temperature	T _c	0	70	°C	
Operating Humidity	OH	5	95	%	
Power Supply Voltage	V _{CC}	0	4	V	
Receiver Damaged Threshold		+5		dBm	

• Table 2- Recommended Operating Conditions

Parameter	Symbol	Min.	Typical	Max.	Unit	Notes
Power Supply Voltage	V _{CC}	3.13	3.3	3.47	V	
Operating Case Temperature	T _c	0		70	°C	
Operating Humidity Range	OH	5		95	%	
Nominal Data Rate			Tx 2488.32 Rx 1244.16		Mbit/s	
Data Rate Drift		-100		+100	PPM	

Note:

1. Specified without connectors
2. Add an additional 0.2dB loss including connectors

Tips:

Due to the COVID-19, sorry that you and our team couldn't visit face to face with each other. In order to make the customers know us more, please visit our VR factory, it is just like you were really standing in our factory.

OPTICO fiber assemblies: <https://www.linked-reality.com/company/15555/en>

• Table 3- Transmitter Optical Characteristics

Parameter	Symbol	Min.	Typical	Max.	Unit	Notes
Optical Center Wavelength	λ_c	1480	-	1500	nm	
Optical Spectrum Width (-20dB)	$\Delta\lambda$		-	1	nm	
Side Mode Suppression Ratio	SMSR	30	-		dB	
Average Launch Optical Power	AOP	+4	-	+7	dBm	BOL, Normal Temperature
		+3		+7		EOL, Over Temperature
Power-OFF Transmitter Optical Power			-	-39	dBm	Launched into SMF
Extinction Ratio	ER	8.2	-		dB	PRBS 223-1+72CID @2.488Gbit/s
Tolerance to Transmitter Incident Light					dB	
Transmitter Reflectance				-10	dB	
Transmitter and Dispersion Penalty	TDP			1	dB	Transmit on 20km SMF
Optical Waveform Diagram	ITU-T G.984.2					Figure 1

Note:

1. Specified without connectors
2. Add an additional 0.2dB loss including connectors

Tips:

Due to the COVID-19, sorry that you and our team couldn't visit face to face with each other. In order to make the customers know us more, please visit our VR factory, it is just like you were really standing in our factory.

OPTICO fiber assemblies: <https://www.linked-reality.com/company/15555/en>

• Table 4- Transmitter Electrical Characteristics

Parameter	Symbol	Min.	Typical	Max.	Unit	Notes
Data Input Differential Swing		200		1600	mV	LVPECL input, AC coupled
Input Differential Impedance		90	100	110	Ω	
Power Supply Current				220	mA	Load free
Transmitter Disable Voltage - Low		0		0.8	V	
Transmitter Disable Voltage - High		2.0		V _{cc}	V	
Transmitter Fault Alarm Voltage - Low		0		0.4	V	
Transmitter Fault Alarm Voltage - High		2.4		V _{cc}	V	

• Figure 1 Transmitter Eye Mask Definitions and Test Procedure

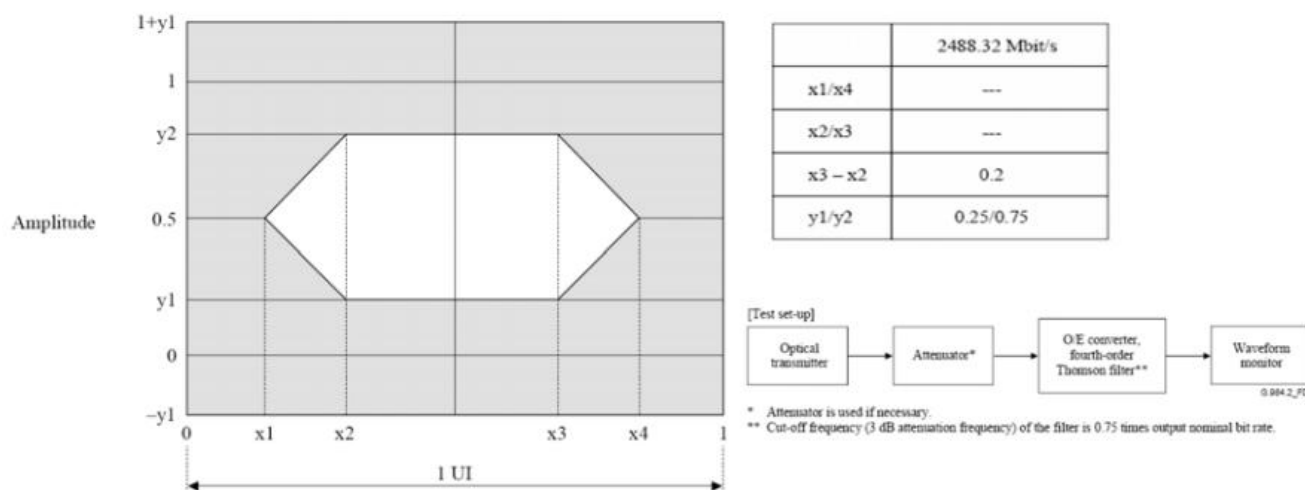

Note:

1. Specified without connectors
2. Add an additional 0.2dB loss including connectors

Tips:

Due to the COVID-19, sorry that you and our team couldn't visit face to face with each other. In order to make the customers know us more, please visit our VR factory, it is just like you were really standing in our factory.

OPTICO fiber assemblies: <https://www.linked-reality.com/company/15555/en>

• Table 5- Receiver Optical Characteristics

Parameter	Symbol	Min.	Typical	Max.	Unit	Notes
Operating Wavelength		1290		1330	nm	
Sensitivity (BOL, Normal Temperature)	SEN			-31	dBm	PRBS 223-1+72CID@1.244 Gbps BER $\leq 1 \times 10^{-10}$
Sensitivity (EOL, Over Temperature)	SEN			-30		
Saturation Optical Power	SAT	-12			dBm	
Dynamic Range		15			dB	Figure 2
Signal Detect Assert Level				-33	dBm	
Signal Detect De-Assert Level		-45			dBm	
Signal Detect Hysteresis		0.5		6	dBm	
Receiver Reflectance				-12	dB	

• Figure 2 Burst Mode Receiver Dynamic Range in GPON System

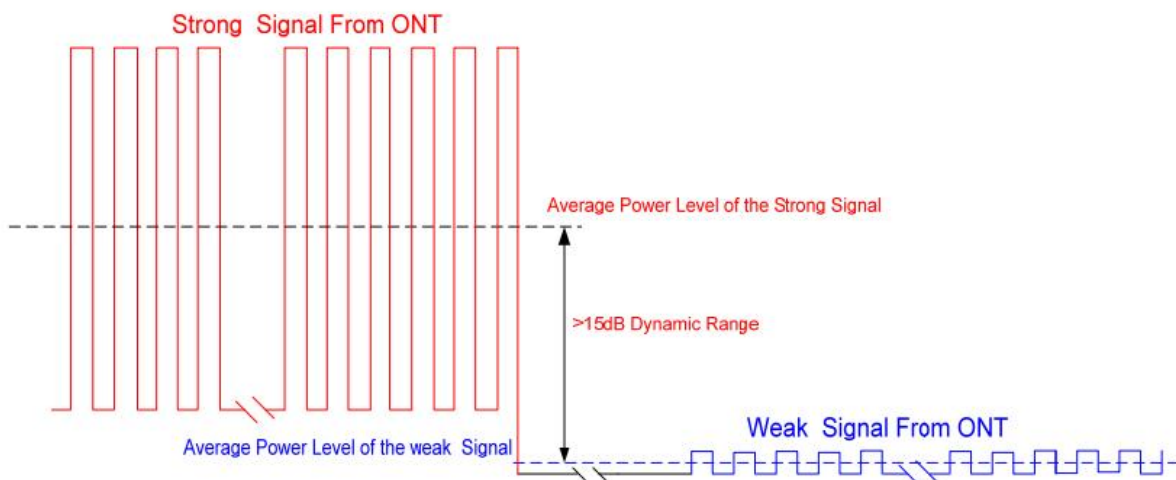

Note:

1. Specified without connectors
2. Add an additional 0.2dB loss including connectors

Tips:

Due to the COVID-19, sorry that you and our team couldn't visit face to face with each other. In order to make the customers know us more, please visit our VR factory, it is just like you were really standing in our factory.

OPTICO fiber assemblies: <https://www.linked-reality.com/company/15555/en>

• Table 6- Receiver Electrical Characteristics

Parameter	Symbol	Min.	Typical	Max.	Unit	Notes
Power Supply Current				350	mA	Load free
Data Output Voltage – Low (-Vcc)		-1.81		-1.62	V	
Data Output Voltage – High (-Vcc)		-1.02		-0.88	V	
Data Output Differential Swing		400		1600	mV	LVPECL output, DC coupled
Reset width	T_{RESET}	16			bits	Figure 2
Reset-Low		0		0.4	V	
Reset-High		2.4		Vcc	V	
Receiver Amplitude Recovery Time	$T_{RECOVERY}$			32	bits	Refer to the Reset signal falling edge
Signal Detect Assert Time				50	ns	
Signal Detect De-assert Time				12.8	ns	Refer to the Reset signal rising edge
Signal Detect Voltage-Low		0		0.4	V	
Signal Detect Voltage-High		2.4		Vcc	V	
RSSI Trigger-Low		0		0.8	V	
RSSI Trigger-High		2.0		Vcc	V	
Optical Signal During Time	T_{ONT}	300			ns	
RSSI Trigger width	T_W	300		$T_{ont} - T_D$	ns	
RSSI Trigger Delay	T_D	0		3000	ns	
I ² C Access Prohibited Time				500	μs	

Note:

1. Specified without connectors
2. Add an additional 0.2dB loss including connectors

Tips:

Due to the COVID-19, sorry that you and our team couldn't visit face to face with each other. In order to make the customers know us more, please visit our VR factory, it is just like you were really standing in our factory.

OPTICO fiber assemblies: <https://www.linked-reality.com/company/15555/en>

• Figure 3 Burst Receiver Timing Sequence

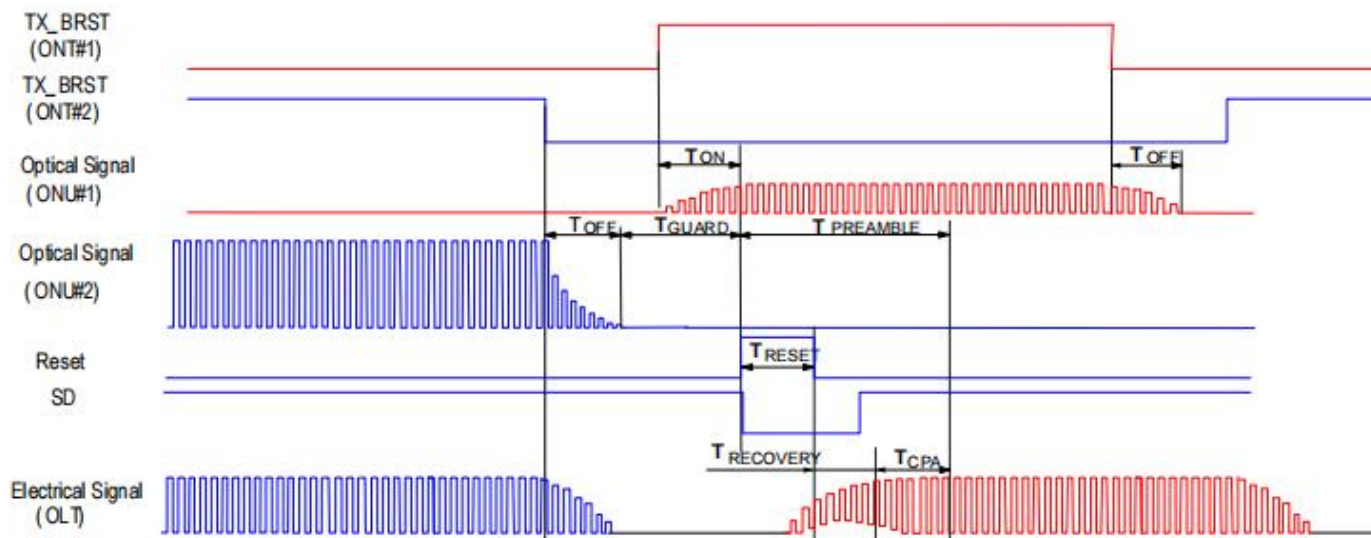

Figure 3 Burst Receiver Timing Sequence

• Figure 4 RSSI TIMING SEQUENCE

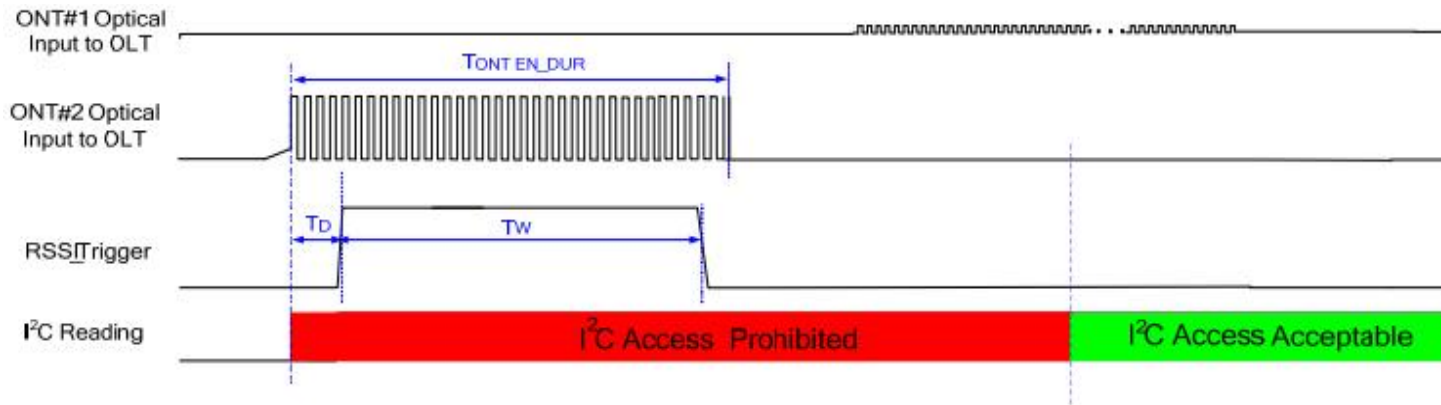

Figure 4 RSSI TIMING SEQUENCE

Note:

1. Specified without connectors
2. Add an additional 0.2dB loss including connectors

Tips:

Due to the COVID-19, sorry that you and our team couldn't visit face to face with each other. In order to make the customers know us more, please visit our VR factory, it is just like you were really standing in our factory.

OPTICO fiber assemblies: <https://www.linked-reality.com/company/15555/en>

• Table 7- Pin Description

Pin	Name	Description	Notes
1	V _{EE} T	Transmitter Ground	
2	Tx Fault	Transmitter Fault Indication	High: abnormal; Low: normal
3	TX Disable	Transmitter Disable	High: transmitter disable; Low: transmitter enable
4	MOD-DEF2	Module Definition 2	The data line of two wire serial interface
5	MOD-DEF1	Module Definition 1	The clock line of two wire serial interface
6	MOD-DEF0	Module Definition 0	Connected to Ground in the transceiver
7	Reset	Receiver Reset	High: reset the receiver
8	SD	Signal Detect	High: signal detected; Low: loss of signal;
9	RSSI Trigger	RSSI Trigger for Transceiver A/D Conversion	High: enable RSSI A/D conversion
10	V _{EE} R	Receiver Ground	
11	V _{EE} R	Receiver Ground	
12	RD-	Inv. Receiver Data Out	LVPECL logic output, DC coupled
13	RD+	Receiver Data Out	LVPECL logic output, DC coupled
14	V _{EE} R	Received Ground	
15	V _{CC} R	Receiver Power	
16	V _{CC} T	Transmitter Power	
17	V _{EE} T	Transmitter Ground	
18	TD+	Transmit Data In	LVPECL logic input, AC coupled
19	TD-	Inv. Transmit Data In	LVPECL logic input, AC coupled
20	V _{EE} T	Transmitter Ground	

Note:

1. Specified without connectors
2. Add an additional 0.2dB loss including connectors

Tips:

Due to the COVID-19, sorry that you and our team couldn't visit face to face with each other. In order to make the customers know us more, please visit our VR factory, it is just like you were really standing in our factory.

OPTICO fiber assemblies: <https://www.linked-reality.com/company/15555/en>

- Figure 5 SFP Recommended Host Board Power Supply Filtering Network

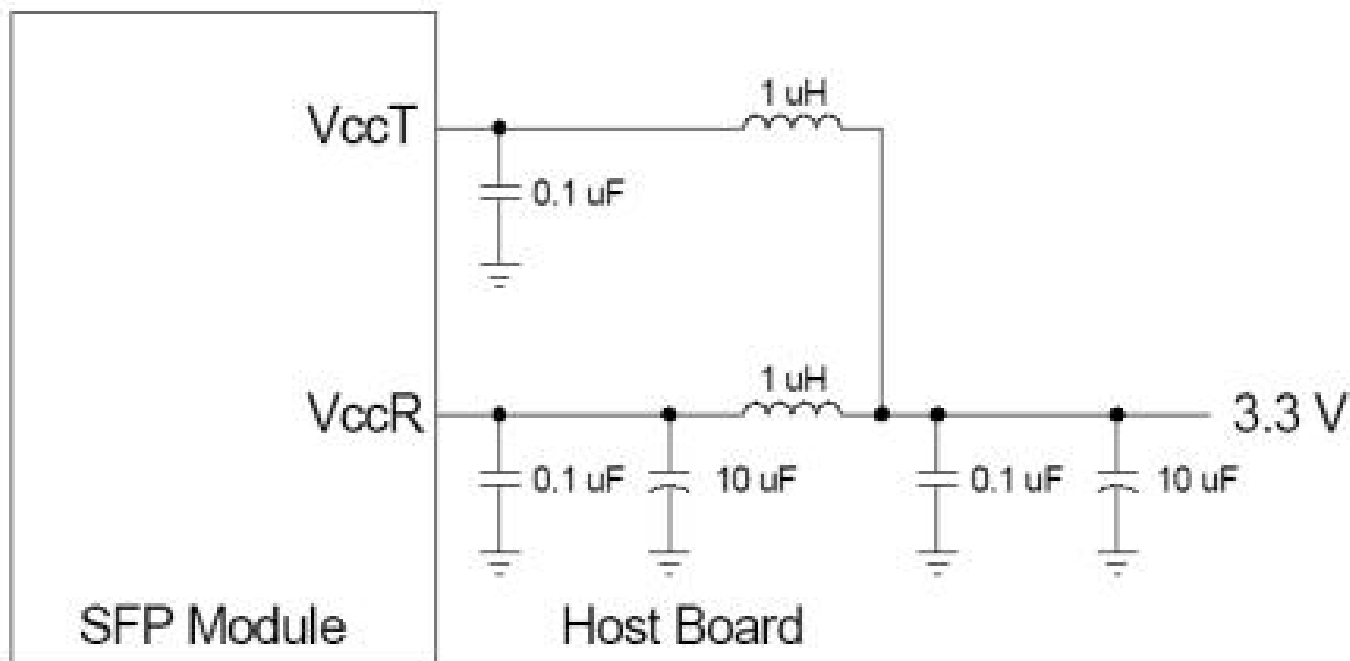

Note:

1. Specified without connectors
2. Add an additional 0.2dB loss including connectors

Tips:

Due to the COVID-19, sorry that you and our team couldn't visit face to face with each other. In order to make the customers know us more, please visit our VR factory, it is just like you were really standing in our factory.

OPTICO fiber assemblies: <https://www.linked-reality.com/company/15555/en>

• Figure 7 Typical Interface Circuit

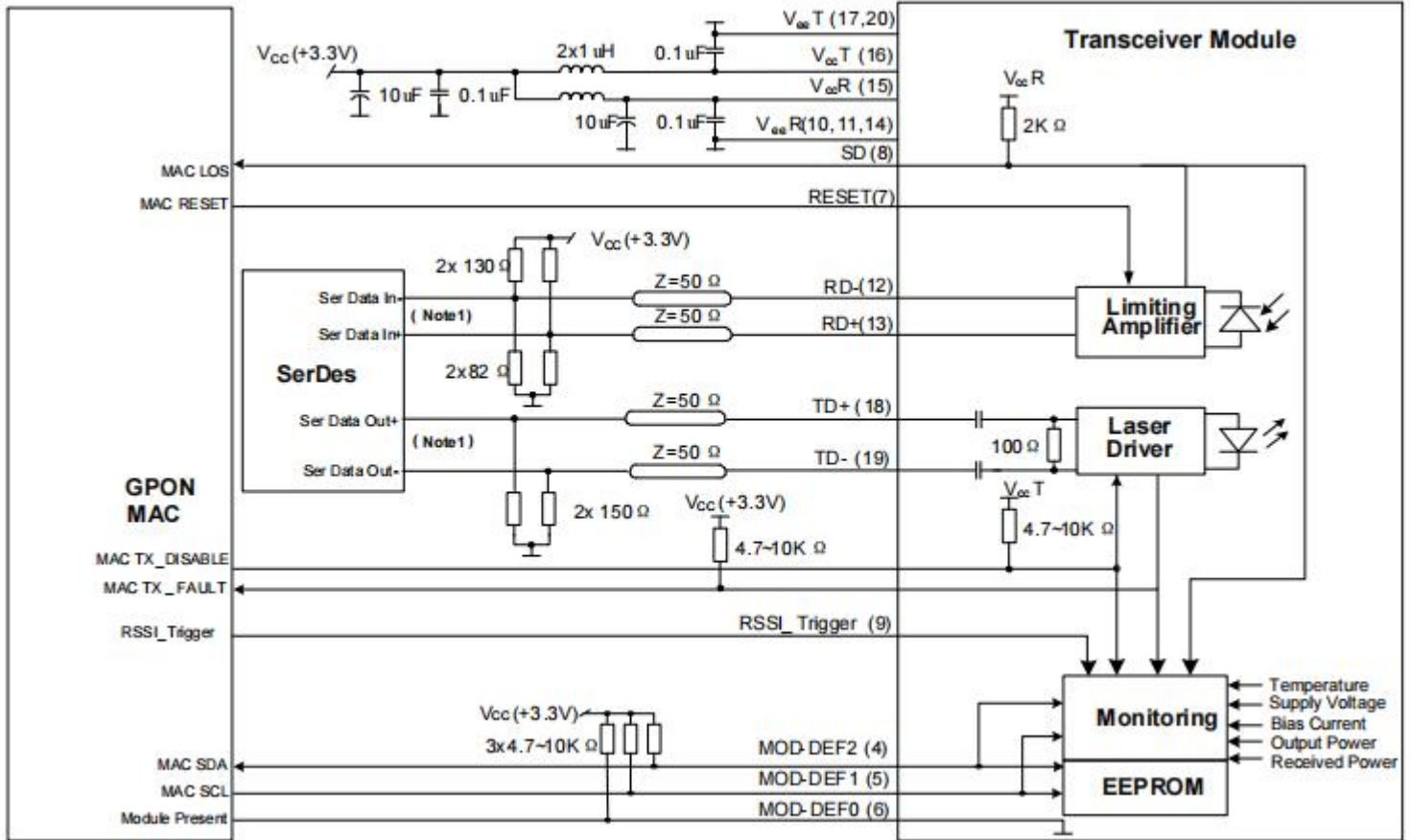

Note:

1. Specified without connectors
2. Add an additional 0.2dB loss including connectors

Tips:

Due to the COVID-19, sorry that you and our team couldn't visit face to face with each other. In order to make the customers know us more, please visit our VR factory, it is just like you were really standing in our factory.

OPTICO fiber assemblies: <https://www.linked-reality.com/company/15555/en>

- Figure 8 Package Outline

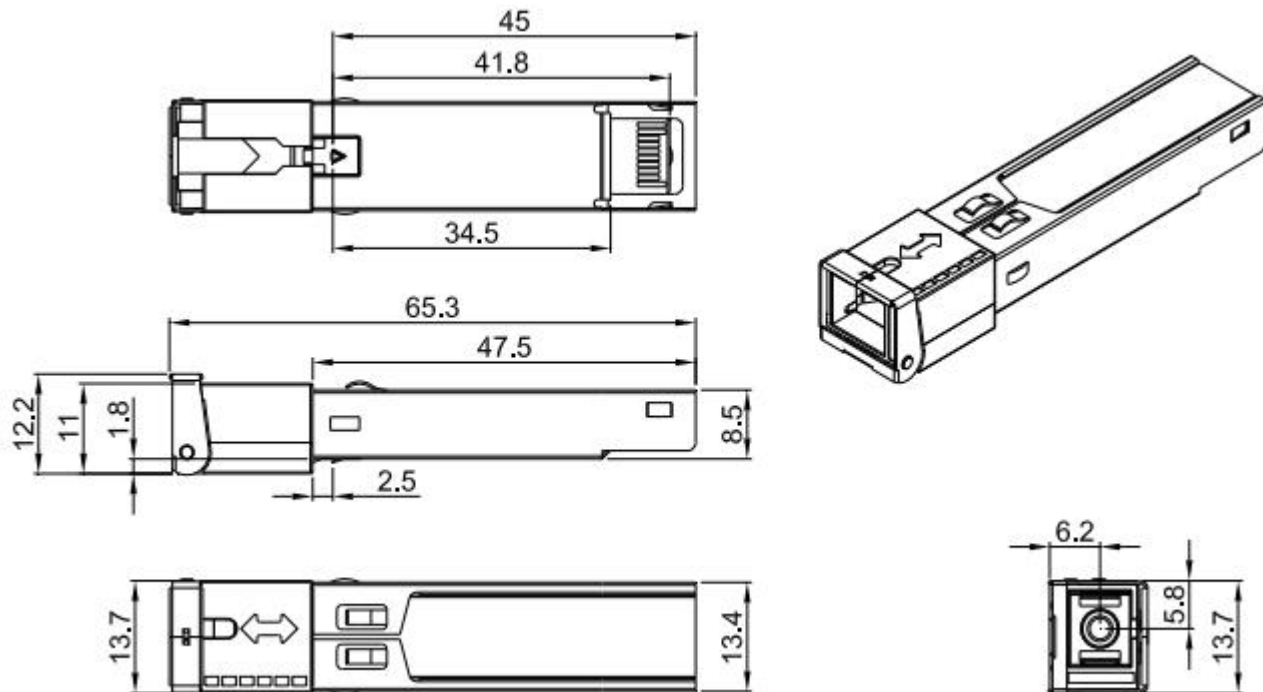

Note:

1. Specified without connectors
2. Add an additional 0.2dB loss including connectors

Tips:

Due to the COVID-19, sorry that you and our team couldn't visit face to face with each other. In order to make the customers know us more, please visit our VR factory, it is just like you were really standing in our factory.

OPTICO fiber assemblies: <https://www.linked-reality.com/company/15555/en>

• Figure 9 EEPROM Memory Map Specific Data Field Descriptions

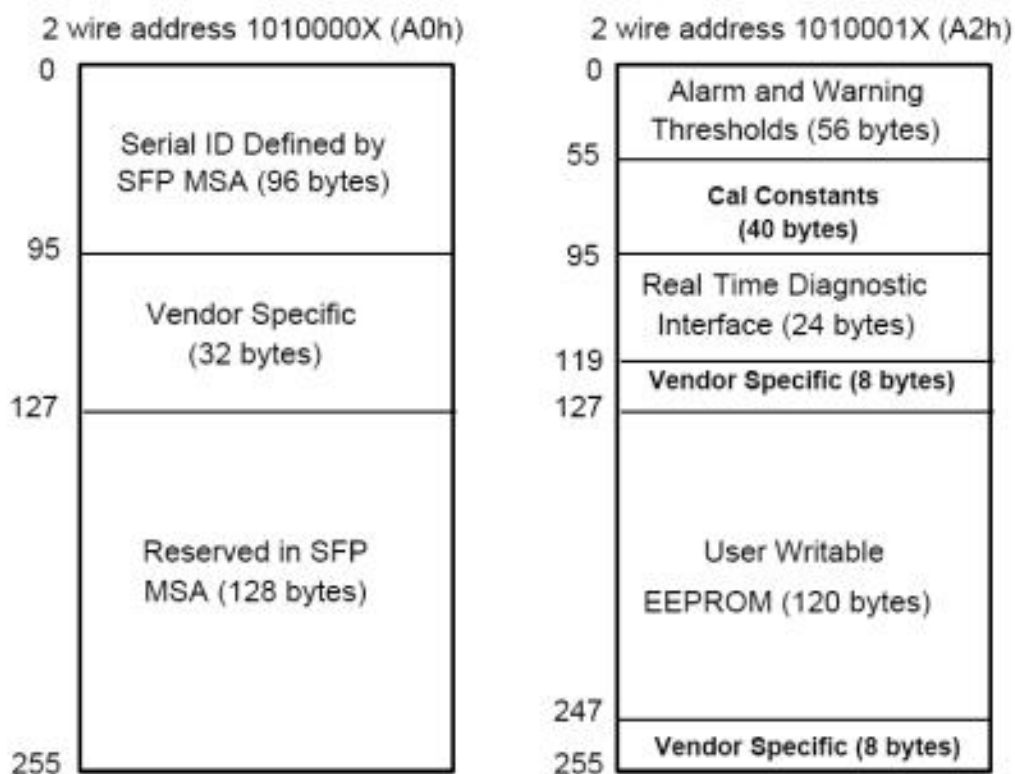

Parameter	Range	Accuracy	Calibration	Notes
Temperature	-40 to 125°C	±3°C	Internal	1LSB = 1/256°C
Voltage	0 to 6.55V	±10%	Internal	1LSB = 0.1mV
Bias Current	0 to 131mA	±10%	Internal	1LSB = 2uA
TX Power	0 to 8dBm	±2dB	Internal	1LSB = 0.1uW
RX Power monitor	-32 to -12dBm	±3dB	External	1LSB = 0.1uW

Note:

1. Specified without connectors
2. Add an additional 0.2dB loss including connectors

Tips:

Due to the COVID-19, sorry that you and our team couldn't visit face to face with each other. In order to make the customers know us more, please visit our VR factory, it is just like you were really standing in our factory.

OPTICO fiber assemblies: <https://www.linked-reality.com/company/15555/en>